

DISTRIBUTED ANTENNA SYSTEMS PLUS SOFTWARE RADIO: RANGE EXTENSION AND OTHER BENEFITS

Steve Muir, John Chapin, Vanu Bose, Jeff Steinheider
Vanu, Inc. Cambridge, MA, USA info@vanu.com

ABSTRACT

A distributed antenna system (DAS) breaks the traditional radio basestation architecture into two pieces: a central processing facility and a set of distributed antennae connected to the central facility by a high-bandwidth network. The DAS network transports radio signals, in either analog or digital form, to/from the central facility where all the basestation processing is performed.

DAS technology can be used simply as a means of physically separating large, power-hungry basestation equipment from the antenna in space and/or power-constrained environments. However, it is particularly attractive when used in combination with a software radio basestation.

In this paper we describe the synergy between these two emerging technologies, and show how each one takes advantage of and amplifies the benefits of the other. We present one particular example of synergy: the Vanu Anywave \ basestation's ability to extend the DAS fiber length limit of a time-slotted protocol such as GSM. The conventional limit of approximately 10 miles for GSM has been overcome to support a DAS fiber network with approximately 85 miles of fiber range.

1 INTRODUCTION

Distributed antenna systems (DAS) have attracted significant interest from cellular service providers in recent years. In a DAS architecture, each antenna site has minimal equipment. Most of the components traditionally colocated with the antenna—the basestation or access point—are moved to a central facility that serves many antenna sites. A typical design uses optical fiber to move analog or digitized RF between the central facility and the remote sites. DAS has been used to provide coverage in airports and convention centers, and in tunnels and similar sites where there is no room for a full basestation at the antenna. DAS is now being considered for outdoor deployment in urban centers, and is evolving to use

innovative wireless links to connect antenna sites to the central processing facility.

There is a strong synergy between DAS and software radio, in particular software radio systems that are capable of input/output of digitized RF samples. Software radios like this, for example Vanu Software Radio, support a DAS architecture where the central facility is entirely digital and can be built completely from off-the-shelf equipment (COTS). A COTS switched network can connect the processing servers at the facility to the antenna sites, or the digitized RF samples can be routed via any innovative backhaul link. The resulting system design offers significant benefits by reducing acquisition, maintenance and operating costs; it also permits far more flexible resource sharing and redundancy than non-SDR DAS designs that reuse traditional basestations in the central facility.

2 APPLICATIONS OF DAS

DAS technology finds applications in any deployment scenario where it is beneficial to separate the basestation equipment from the associated antennae. In some cases the benefit of doing so is primarily financial, such as reduction of operating costs by maintaining one large facility rather than several small ones. In other cases DAS is used to overcome constraints imposed by the physical environment e.g., lack of space for a conventional basestation, or inappropriate environmental conditions.

2.1 Basestation Hotels

A basestation hotel is a novel network architecture where a number of basestations and their supporting equipment are located in a central facility. A DAS network connects the basestation hotel to a number of antennae spread out over a geographic region, such as a metropolitan area. The hotel concept has attracted a great deal of attention from cellular operators who are interested in the potential economic advantages of colocating multiple basestations in a single facility and minimizing the footprint (space required) of each antenna. However, this concept has not yet been proven with large-scale deployments.

2.2 Enterprise/In-Building Coverage

DAS can also significantly improve network coverage within an enterprise location, particularly inside buildings. The enterprise's network operations unit is able to deploy the basestation hub in a central location while connecting a number of low-footprint, low-power antennae throughout the building or campus. Thus the operations unit is able to perform maintenance on the basestation equipment at a convenient central location, while also providing broad coverage for the facility. Finally, with appropriate design of the antenna units, they can use Power-Over-Ethernet, or similar, to minimize installation cost.

2.3 Neutral Hosting

A DAS network provides an ideal basis for a neutral host service, in which one entity operates a network on behalf of multiple cellular carriers. Traditional neutral-host systems such as those installed in airports and convention centers were antenna-only systems; carriers installed their own basestations. More recently, business models have emerged where the neutral host provider also installs and operates the basestations.

Neutral host applications have a particular synergy with software radio when supporting multiple wireless protocols on a common hardware platform. In this scenario the provider is able to take advantage of the flexibility of software radio to dynamically alter resource allocation between protocols.

3 EVOLUTION OF DAS TECHNOLOGY

Distributed antenna systems have been built using a variety of technologies as the basis for signal distribution. In this paper we only consider fiber-based systems, but a number of alternatives are being considered for DAS: free-space optics, microwave, millimeter-wave, and broadband over power-line.

3.1 Analog Interconnect

Analog DAS designs have been developed by numerous vendors, e.g., Andrew [1]. Such systems typically are much simpler than digital systems, and thus provide a lower cost option for network operators. Unfortunately analog transmission over fiber suffers from various drawbacks when compared to digital alternatives e.g., inability to share fiber with non-DAS applications. Furthermore, analog signals transmitted over long distances suffer from signal degradation, whereas digital systems typically do not. Thus analog DAS are popular in short-range applications, such as in-building systems.

However, an interesting development in the analog DAS domain is the wide-band system that can transmit a broad swath of spectrum, typically several gigahertz, over fiber without requiring down-conversion [2]. This allows the DAS network to carry a range of wireless signals over a single fiber network.

Analog DAS networks are also unable to directly interface with the digital interfaces of a BTS, and thus are not directly relevant to our discussion of synergy between DAS and software radio; hence we do not discuss them further in this paper.

3.2 Digital Interconnect

There have been a number of different digital interconnects used between the basestation and remote antenna(e) for DAS. In the past, some vendors such as ADC [3] have used proprietary protocols for transmitting RF data over fiber, while others have utilized standard technologies such as SONET.

Digital DAS has significant advantages. The digitized RF data can flow directly to the basestation, eliminating redundant conversions to/from analog, in turn reducing hardware cost and minimizing noise introduced by such conversions. Analog DAS typically must transport a wide band in order to capture a number of channels; digital DAS channelizes at the antenna and thereby saves interconnect bandwidth. In cases with multiple antennas near to each other, analog DAS typically requires multiple fibers, while digital DAS can multiplex all the signals onto one link.

Current and future efforts to develop open standards for a digital interface between a basestation and its RF head(s)—such as OBSAI [4] and CPRI [5]—are likely to make it even easier to connect basestations directly to a DAS system.

Given a digital interconnect, there is the choice of whether to use a general-purpose protocol or one specific to DAS. Using a general-purpose protocol reduces the cost of equipment and enables DAS data to be carried on preexisting networks where appropriate. On the other hand, a specialized protocol can support clock distribution in addition to data transport, and because the protocol is optimized for a particular application, the endpoint implementation may be simpler than using a general network protocol.

A significant advantage of a general-purpose protocol is that the DAS interconnect can easily be switched. Switching enables multiple paths to an antenna, for example a ring to reduce single points of failure, and multiple basestations at the hub can connect to a given antenna. Switching is possible for specialized protocols but vastly more expensive since all the necessary equipment must be developed.

3.3 General Packet-Based Interconnect

At Vanu we are particularly interested in the use of general packet-based protocols, such as Gigabit Ethernet (GigE) and 10-Gigabit Ethernet (10GigE), as the basis for a DAS [6]. GigE is commonplace on even low-end PC servers and network infrastructure equipment, and variants are available for a broad range of physical media and distances: copper and multi-mode fiber for local area/short-range applications (up to 500m for enterprise and in-building applications), or single-mode fiber providing up to 70km range.

Packet-based protocols offer various benefits over streaming protocols. A packet-based network readily supports multiplexing of sample streams that have unrelated data rates. This is valuable for multi-standard systems. A packet-based network also allows the use of in-band control, for example of frequency hopping, which simplifies overall system design.

The use of general-purpose protocols, such as IP, is of particular interest to us since they are readily available in the software radio OS. Such protocols include features that are likely to be desirable in complex DAS networks, such as switching, routing, multiplexing of data streams onto physical links, and flow control. In addition, the widespread use of these protocols means that development, monitoring and diagnostic/troubleshooting tools are readily available and thus inexpensive.

The single biggest advantage of using a general-purpose packet network is the cost and availability of network infrastructure equipment. This makes it possible for a DAS network operator to utilize low-cost commodity equipment to build a high-performance switched network.

An open question regarding the use of packet-based interconnects is what the appropriate protocol for communicating RF samples is. Minimizing the number of protocol layers used is advantageous in terms of reducing latency and obtaining maximum bandwidth efficiency, but additional layers are likely to be needed to support features such as flow control, clock synchronization, and routing of packets in switched networks. Although most DAS networks today utilize point-to-point links in a star configuration, we anticipate that switched networks (with some degree of redundancy to provide fault tolerance) will become more common, particularly when implemented using packet-based technologies that are aimed at such deployments.

4 SYNERGY BETWEEN SDR AND DAS

As described earlier in Section 2.3, the flexibility and upgradeability of software radio increase the benefits and feasibility of certain DAS applications, such as basestation hotels and neutral hosting.

However, the strongest synergy between software radio and DAS arises from the fact that a software radio system based upon off-the-shelf compute-server technology makes a basestation hotel essentially into a normal IT-style server farm. Management of this is considerably simpler and cheaper than the specialized management of a basestation deployment.

For example, the low cost of off-the-shelf servers make it economical to provide additional servers for redundancy purposes. With a suitably designed server infrastructure and DAS network these servers can be configured to automatically replace failed components. Moreover, high reliability can be achieved with one backup server for multiple primaries, significantly reducing cost compared to the full hardware duplication used when a single basestation must be made redundant. This approach is particularly beneficial in a multi-standard system, because backup servers can be dynamically configured as replacements for any of the supported standards, rather than requiring specialized backup hardware for each.

A server farm design also makes hardware replacements and upgrades cheaper. Capacity upgrades become as simple as adding more servers or replacing old servers with higher-capacity versions, since all servers access the DAS network through a shared access network.

4.1 Advanced designs and features

Combining a general packet-based interconnect that switches traffic between antennae and multiple basestations (section 3.3) with a software radio server farm creates a DAS system that supports a number of advanced system designs and features.

The dynamic provisioning capability of software radio—the ability to rapidly reconfigure the waveform load of a server—combines with the flexibility of switched DAS to enable rapidly shifting processing capacity across cell sites. For example, an urban basestation hotel might migrate capacity from commuter transportation facilities during morning rush hour, to business and financial districts during office hours, then to residential areas in the evening.

Similarly, the multiple servers can perform load-sharing when adding a new waveform to the system. In the early days of offering a new service, relatively few customers will be active in any given cell at one time. The server farm need only allocate processing capacity to each cell for the new service in proportion to the number of active customers at that point in time. Buildout costs thereby grow with usage (revenues) rather than requiring a major investment simply to achieve sufficient coverage to attract the first customer.

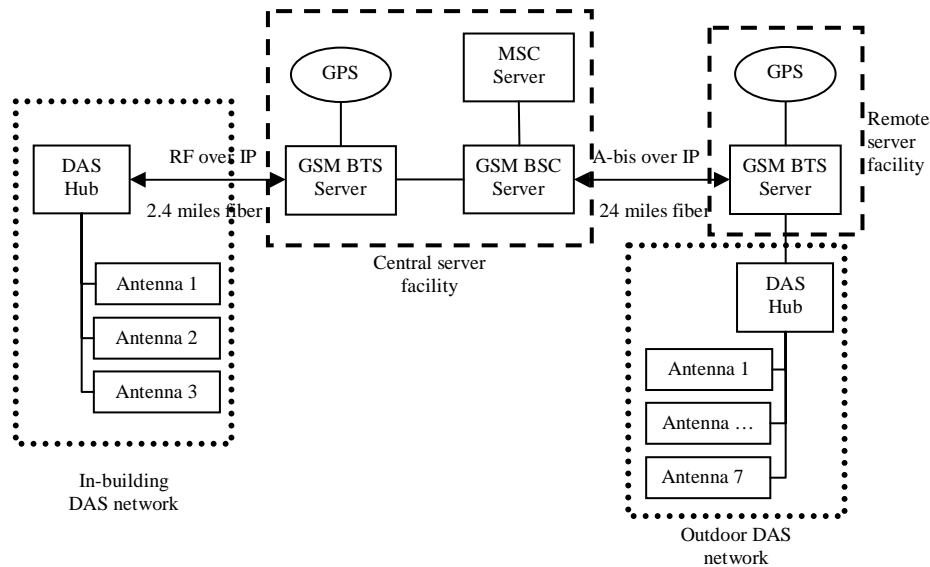

Figure 2: Schematic of Vanu Software Radio Testbed

The data coming from an antenna can easily be replicated (in the switch or in a server). This enables the central facility to add new services with minimal changes to existing hardware or software. Potential services include position determination (for E-911 and location-aware services), intruder detection, QOS measurement and network optimization. With the exception of E-911, the computing resources allocated to these tasks can be reallocated to perform signal processing when system load is high. This both reduces the cost of deploying these new services, and gives the operator a way to earn revenue from basestation signal processing capacity required for busy hour but not needed for traffic most of the day.

5 THE VANU DAS TESTBED

We have built a small software radio testbed using two DAS networks. Figure 1 shows the structure of the software radio testbed. Each DAS network consists of a hub that connects multiple antennae to the BTS using single-mode optical fiber; the DAS equipment used in the current testbed transmits a wideband digitized signal over the fiber using the vendor's proprietary protocol. The indoor DAS network is connected to a BTS at the central server facility over 2.4 miles of fiber. The central facility also includes both the BSC and MSC for the testbed. The outdoor DAS network is connected to a remote server facility, since the 24 mile fiber between the central and remote facilities incurs too much latency for transmission of RF samples in some waveforms. The remote BTS uses an A-bis/IP-over-fiber backhaul to the central facility where it connects to the BSC.

Note that the GPS associated with each BTS is only necessary to provide a stable clock reference.

The testbed currently supports internal engineering efforts, i.e., development and validation of new software radio components, and we allow partners, and potentially third-parties, to leverage the testbed infrastructure for their own research and development purposes.

The testbed also serves to validate the DAS architecture, demonstrates software radio technology in realistic settings, and generates a large volume of radio and network traffic for both live system evaluation and subsequent trace-driven testing. Incorporation of a wide range of technologies and components into the testbed creates an ideal environment for interoperability testing.

One interesting aspect of the outdoor DAS network is that our experimental network traffic is carried over the same DAS network as live traffic for a commercial cellular operator. In the current system the two transmitted signals are digitally combined into a wideband signal at the DAS network's hub, while the signal received by the hub from the DAS network is split into separate channels. In the future we expect to also use a packet-based DAS network that allows us to transmit separate channels to the remote antennae and combine those channels at the antenna, thus reducing bandwidth usage.

Future phases of testbed construction are expected to include urban street-level coverage solutions and additional in-building systems, plus the use of WiMAX backhaul technology between sites. Support for a variety of waveform implementations will be a key part of the testbed in the future, allowing validation of many of the DAS techniques described

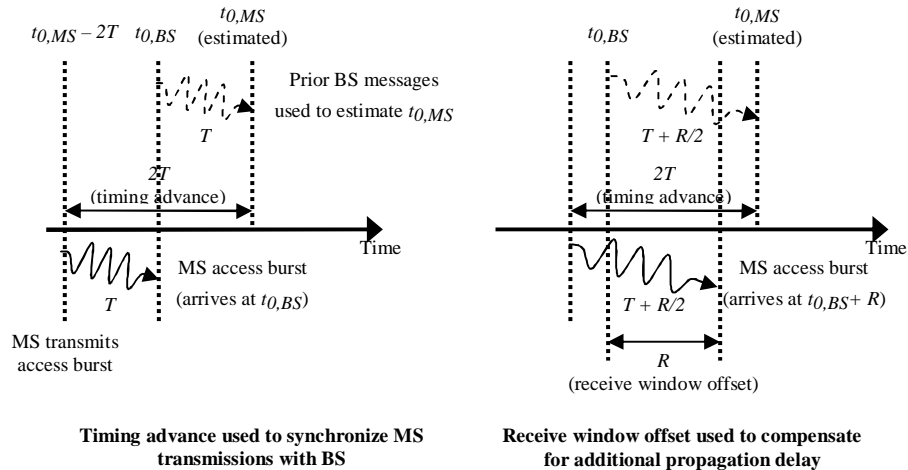

Figure 2: Use of Timing Advance and Receive Window Offset in GSM

earlier, such as support for multistandard, channelized transmission and disparate data rates.

6 EVALUATING GSM RANGE EXTENSION

One practical limitation on the deployment of DAS technology is the additional latency that the DAS network adds to the radio propagation delay between mobile system and basestation. Given the reduced propagation speed of signals through fiber compared to over-the-air transmission, any limitation imposed by the wireless waveform on maximum propagation delay can significantly constrain the maximum fiber length supported.

Extending this range is critically important in increasing the cost-effectiveness of DAS solutions: increased maximum fiber length allows a single hub to support more remote antennae; in deployments where hub cost is a significant factor such a change makes a DAS network much more economically attractive.

6.1 GSM Timing Constraints

Error! Reference source not found. depicts the relationship between basestation and mobile station timing in a GSM system.

The mobile station (MS) listens to the transmitted downlink signal and estimates the beginning of each timeslot, where a timeslot consists of 156 symbol periods. Let $t_{0,MS}$ be the MS-estimated time corresponding to the beginning of a particular timeslot; this will be T (micro)seconds after the basestation (BS) actually transmitted the first symbol in the same timeslot i.e., T is the one-way propagation delay from BS to MS. If the MS were to subsequently transmit an access burst at $t_{0,MS}$ that burst would be received by the BS at time $(t_{0,MS} + T)$, since the propagation delay

from MS to BS is also T . Therefore the MS must actually transmit the access burst at time $(t_{0,MS} - 2T)$ if that burst is to arrive at the BS simultaneously with the transmission of the same timeslot by the BS, which is the degree of synchronization required by the GSM waveform. This value, $2T$, is measured by the BS, quantized to an integer number of symbols, and reported to the MS as the *timing advance* (TA) [7].

The maximum TA value allowed in GSM is 63 symbols, which corresponds to about $232\mu s$. Any access burst transmitted by an MS that has a propagation delay to the BS greater than half of this value will be received outside the timeslot 0 window that is considered valid by the BS, and thus the MS will be ignored; we disregard the unlikely case of an access burst being received in timeslot 0 of a subsequent frame since such pathological behavior would require an inordinately large delay.

The Vanu Anywave basestation is able to compensate for delay larger than normally allowed by adjusting the offset within the received sample stream at which the BS expects timeslot 0 to begin; let us call this value the *receive window offset*, R . This extends the range at which an MS can successfully communicate with the BS, but since the TA value is still constrained to be 6 bits the size of the window does not change, and thus an MS that is very close to the BS will no longer be able to communicate. Hence the radio coverage area changes from a circular region to a ring, where the inner radius of the ring is determined by R ; this technique must therefore be used carefully when compensating for over-the-air delay. However, it is perfectly suited to fiber-based DAS networks where there is a fixed length of fiber i.e., additional delay, in the signal path. In addition, this approach does not sacrifice system capacity to achieve increased range, unlike alternative methods

that utilize additional timeslots at the expense of prohibiting calls in those timeslots [8].

6.2 Experimental Validation

We have used the DAS testbed to validate and demonstrate our range extension technology for GSM in a real-world, rather than laboratory, environment. The outdoor DAS network connects the basestation complex, located at a central hub location, to a total of 7 antennae in a star configuration, where the length of fiber from hub to antenna is between 13 and 16 miles depending upon the specific antenna. Due to the propagation delay of the fiber this creates a round-trip latency of about $280\mu s$, which exceeds the acceptable delay for a standard GSM system.

However, Vanu's GSM timing advance technology allows us to adjust the relative timing of the received and transmitted data streams to compensate for this delay, and unmodified GSM handsets can then connect to the basestation and operate normally. Unlike other timing advance technologies this does not require that certain time slots be utilized to support this mode of operation, and thus the system capacity is not reduced.

We used a two-step process to verify the effectiveness of the range extension technology at a combined fiber range of 85 miles as follows:

1. The DAS hub device was configured to add a one-way delay of $550\mu s$ (the maximum configurable in the hardware), corresponding to a distance of about 69 miles, to the signal from the Vanu Anywave basestation. The appropriate timing advance parameters were applied to the BTS, and we verified that mobile handsets functioned correctly.
2. About 35 miles of fiber was added to the Vanu Anywave's connection to the DAS hub, and the hub's additional delay reduced by the corresponding amount in order to maintain a constant delay equivalent to 85 miles of fiber (35 miles between BTS and hub, 34 miles simulated, 16 miles in DAS network). Again we verified the correct functioning of mobile handsets.

The testbed not only provides a means for engineers to verify correct functionality over a range of configurations, but those same configurations can be readily demonstrated to customers in real-world environments rather than a small lab deployment.

Although we demonstrated the use of range extension for GSM, similar techniques could be applied to other waveforms. The iDEN waveform in particular is expected to benefit from this approach.

7 CONCLUSIONS

Distributed antenna systems and software radio are two emerging technologies that achieve considerable synergistic benefits when deployed together. A system combining state-of-the-art technology in both domains provides wireless operators unmatched flexibility in support for multiple waveforms and dynamic provisioning of radio resources over very large geographic areas. At the same time such a system achieves considerable CAPEX savings by leveraging commodity server technology, and reduces OPEX by centralizing those components.

The Vanu Software Radio testbed is a small-scale DAS network that integrates a number of novel technologies into a system with both indoor and outdoor coverage. This system provides a realistic environment for development and interoperability testing, and also serves to demonstrate the unique capabilities of and synergies between DAS and software radio.

8 REFERENCES

- [1] Andrew Britecell Fiber Distributed Antenna System, <http://www.andrew.com/products/inbuilding/britecell/faq.aspx>
- [2] ZinWave Unified Wireless Infrastructure, <http://www.zinwave.com/solutions.htm>
- [3] ADC Digivance NXD Digital Distributed RF, <http://www.adc.com/productsandservices/wireless/>
- [4] Open Base Station Architecture Initiative (OBSAI), <http://www.obsai.org/>
- [5] Common Public Radio Interface (CPRI), <http://www.cpri.info/>
- [6] J. Chapin, G. Britton, B. Kubert, "RF over Ethernet for Wireless Infrastructure", *2005 SDR Forum Technical Conference*, November 2005.
- [7] GSM Technical Specification 05.10, "Digital cellular telecommunications system (Phase 2+) (GSM); Radio subsystem synchronization."
- [8] GSM Technical Specification 03.30, "Digital cellular telecommunications system (Phase 2+) (GSM); Radio network planning aspects."